



ERCCIS



Cornwall

## Homes for Wildlife

As well as wildlife-friendly management of your garden and leaving natural features like piles of dead wood and leaves, you can also encourage a variety of creatures by providing artificial sites for nesting, shelter and hibernation. You can buy - or better still, make - all sorts of homes for wildlife, often using recycled odds and ends, which may benefit everything from ladybirds to hedgehogs!

Here are some ideas for creating a few simple 'creature features':

### Block of wood:

Drill holes of various diameters (around 5-10mm diameter and 9cm deep) into blocks of wood or logs and place in sheltered parts of the garden. Make sure the holes are drilled slightly upwards into the wood so that they don't fill with rain water. Provides a useful winter home for various minibeasts such as solitary bees, solitary wasps, beetles, spiders and ladybirds.



### Lacewing chamber:

Cut the bottom off a large plastic bottle and fill it with a strip of rolled up corrugated cardboard, slightly shorter than the length of the bottle. To keep the cardboard in place, push a piece of thin wire, a twig or some string through holes about 5cm above the base. Tie string around the top of the bottle and hang at shoulder height in dense foliage. Best put up by mid August and preferably near windows as lacewings are attracted to house lights.



Photo: Tamara Weeks

### Natural features.....

**Dead stems:** Many insects, including beneficial ladybirds and lacewings, like to overwinter in the hollow stems of thistle, teasel, angelica, fennel etc. If you dead-head the plants this will enable easier access. Alternatively cut the stems back and stack them in a dry sheltered spot.

**Dead vegetation and leaf litter:** It is helpful to leave at least some dead plant material in your garden as it can be used as a place for hibernation and breeding.

**Log piles:** These attract a range of wildlife e.g. shelter for invertebrates, amphibians and small mammals and a source of food for birds. Use logs of different sizes and from various species of broadleaved trees, with the bark left on if possible. Position in a partly shaded spot, such as under a tree or in a shady corner. Place the logs on or partly in the soil to retain moisture and bury some vertically to make the pile attractive to even more creatures.



Photo: Tamara Weeks

### Stick case:

Gather a bunch of garden canes or hollow stems of bamboo or hogweed to make an effective and simple home for insects. Diameters of around 5-8mm are best, cut into 10-20cm lengths. Secure bundles together with string or wire and hang at various heights in sheltered, sunny spots on tree trunks or fences. Alternatively, put them in a long cylindrical container such as an old piece of piping (sealed at one end to prevent a wind tunnel forming) or within a wooden frame as pictured.



Photo: Tamara Weeks

**Queen bumblebee chamber:** Take an earthenware flowerpot (9-10cm depth) and fill with loose soil. Bury horizontally so that the bottom hole shows or bury completely and attach a 2-3cm length of hosepipe which pokes out of the soil.

### Toad shelter:

Also useful for frogs and newts! In a grassy area dig a chamber 3-4cm deep with a sloping entrance trench and cover with a paving stone.

Or use an old plant pot about 20cm in diameter. Make a semi-circular entrance in the lip of the pot, 8cm wide by 4cm deep. Drill a few holes where the entrance will be and gently tap out with a hammer. Place upside down in a shady undisturbed area such as below a hedge or behind a compost heap, and put well-rotted leaves or grass soaked with water inside for extra shelter. In dry weather water around the pot and pour a little water through the top.

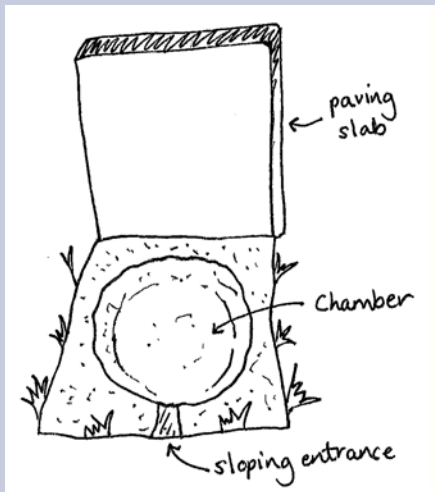

See the separate sheets for information on boxes for birds and bats.

### You could also incorporate several of these ideas to make a 'wildlife tower' that provides homes for many different creatures....

#### Where?

Most invertebrates and amphibians like cool, damp conditions, so siting the structure in semi-shade, alongside a hedge, tree or long grass will enable small creatures to find it more easily. Put tubes for solitary bees on the sunniest side of the structure or elsewhere in the garden. Choose a level surface and place bricks or other levelling materials underneath to create a firm base before building upwards, as the finished tower may end up being quite heavy.

#### How?

Old wooden pallets form the main structure and are filled with ventilation bricks, garden canes, guttering pipe and tubes stuffed with straw, garden cuttings and other natural materials found in the surrounding area. This creates lots of different habitats for invertebrates, amphibians and small mammals, and raising the bottom pallet on bricks provides a larger space for hedgehogs. All the pallets are tied together securely and the whole structure is covered with roofing felt and roof tiles to prevent water getting in.

### Hedgehog hibernaculum:

All a hedgehog needs for the winter is an undisturbed area away from the elements. Even a pile of leaves and twigs in the corner of the garden would be tempting to a homeless hedgehog.

To make a simple home, take an untreated wooden box (approximately 40cmx40cmx50cm) and place it in a quiet corner. Cut two side air vents about 15cm by 5cm and an entrance about 15cm in diameter. Fill with shredded newspaper, dry leaves, straw or other pets' bedding and cover with a pile of logs, twigs, leaves and garden debris. Instead of a wooden box you could simply use a thick cardboard box, covering the top with a plastic bin liner.

The British Hedgehog Preservation Society (tel: (01584) 890801, [www.britishhedgehogs.org.uk](http://www.britishhedgehogs.org.uk)) has details of more permanent hibernation homes (like that pictured below). It is important to follow an approved design to allow sufficient ventilation.

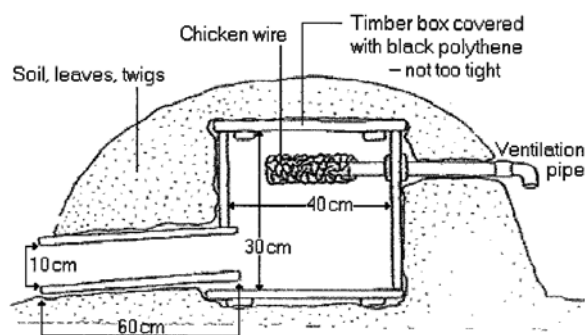

A wildlife tower. Photo: Alison Forward

#### For further information and advice:

Wildlife Information Service  
Environmental Records Centre for Cornwall  
and the Isles of Scilly (ERCCIS)  
Five Acres, Allet, Truro, Cornwall TR4 9DJ

Tel: (01872) 240777 ext 250  
Email: [wis@cornwallwildlifetrust.org.uk](mailto:wis@cornwallwildlifetrust.org.uk)  
Web: [www.ercis.co.uk](http://www.ercis.co.uk)

#### Other useful contacts:

- BugLife: [www.buglife.org.uk](http://www.buglife.org.uk)
- Bumblebee Conservation Trust [www.bumblebeeconservationtrust.co.uk](http://www.bumblebeeconservationtrust.co.uk)
- British Hedgehog Preservation Society [www.britishhedgehogs.org.uk](http://www.britishhedgehogs.org.uk)
- Earnest Charles: [www.ernest-charles.com](http://www.ernest-charles.com)
- Vine House Farm: [www.vinehousefarm.co.uk](http://www.vinehousefarm.co.uk)

#### Get involved:

Submit your garden wildlife records at [www.ercis.co.uk/wildlife\\_recording](http://www.ercis.co.uk/wildlife_recording)

Become a member of Cornwall Wildlife Trust at [www.cornwallwildlifetrust.org.uk](http://www.cornwallwildlifetrust.org.uk)